

DESIGN NOTES

Isolated Flyback Converter Regulates Without an Optocoupler

Design Note 260

Robert Sheehan

Introduction

Designing an isolated power supply can be a daunting task. Optocouplers, secondary-side error amplifiers and frequency compensation can send you scurrying to your distributor catalog to find a module. Fortunately, there are new IC solutions that make isolated power much simpler and less expensive. Here is a gem of a circuit that takes the headaches out of your isolated power supply design task and at a small fraction of a module's cost.

The Design Criteria

- Input Voltage: 100V DC to 300V DC
- Output Voltage: 5V
- Output Current: 100mA to 1A
- Regulation: $< \pm 3\%$ total line and load
- Efficiency: $> 70\%$ at full load
- Isolation: 500V DC
- Size: 1.5" \times 2" \times 0.5"
- Cost: Under \$10 for total solution

Circuit Description

A flyback topology was chosen that allows for wide variations of input voltage and output current. At the heart of the circuit is the LT[®]1725 isolated flyback controller. This is a fixed frequency, current mode PWM controller. It drives the gate of an external MOSFET and is powered from the third (bias) winding of the flyback transformer.

The bias winding also provides output voltage feedback information. This is done directly through a resistive divider, without any rectification or filtering. The unique features of the LT1725 allow regulation to be maintained well into discontinuous mode operation (light load).

The transformer is an EFD15 using a gapped ferrite core. The primary inductance is 976 μ H and the turns ratio is 10:1. The input and output capacitors are aluminum electrolytic for low cost. This provides a high degree of damping at the input and easy frequency compensation for the output. The standard level MOSFET is a D-PAK

LT, LTC and LT are registered trademarks of Linear Technology Corporation.

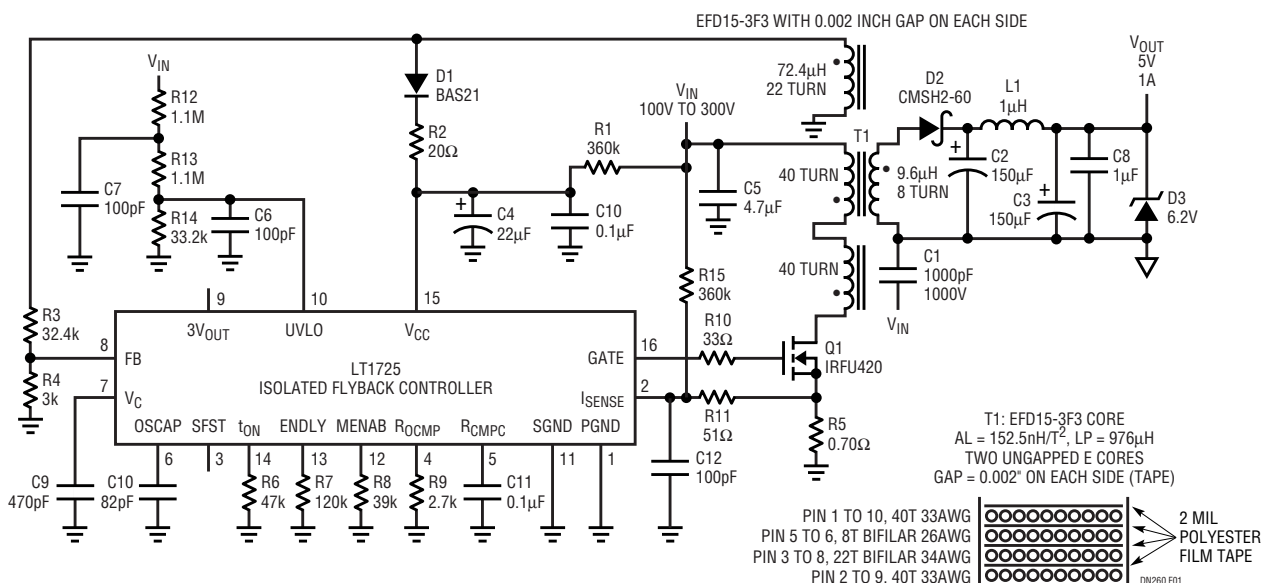

100V_{IN} to 300V_{IN}, 5V_{OUT} at 1A Isolated Flyback Power Supply

IRFU420 rated for 500V. It is chosen for low gate charge to minimize switching losses. The output rectifier is a CSMH2-60 rated for 2A at 60V and is sized to handle continuous short-circuit current.

Circuit Operation

Upon application of input power, R1 trickle charges C4, applying a voltage to the V_{CC} pin of the LT1725. When the voltage at V_{CC} reaches 15V, the LT1725 turns on and begins switching the gate of Q1. With each switch cycle, energy builds in T1 and the output voltage begins to rise. The voltage across the output winding is reflected into the bias winding by the transformer turns ratio. When this voltage reaches about two thirds of the final output voltage, D1 conducts and provides power for the LT1725 from the bias winding. C4 is sized to provide the power for the LT1725 while the output voltage is ramping up. Too low of a value for C4 results in the converter cycling on and off with a sawtooth voltage on the output and across C4. An added benefit of this type of trickle-charge start-up circuit is lower power dissipation during short circuits. With a sustained output short, the converter harmlessly cycles on and off at a low frequency until the short is removed, restoring normal operation. R13 and R14 set input undervoltage lockout at 85V. This prevents operation at a lower input voltage that could overload the input supply.

The operating frequency is set to 120kHz by the 82pF capacitor at the OSCAP pin. This is a reasonable frequency to keep the switching losses relatively low when operating at higher input voltages.

R3 and R4 sample output voltage feedback from the bias winding. The feedback amplifier inside the LT1725 looks at the flyback signal only while the output rectifier, D2, is conducting. This ensures a good sample of the output voltage, maintaining accuracy over a wide range of

operating conditions. Adjusting the value of R9 compensates output voltage load regulation. Resistors R7 and R8 allow the timing of the feedback amplifier sampling to be tailored for specific applications. Frequency compensation is accomplished by a single 470pF capacitor at the V_C pin.

Current is sensed at the MOSFET source, using a ground referenced signal. Leading edge spikes on the current sense signal are ignored due to the current sense amplifier's blanking time, set by R6. R15 introduces a DC offset that is proportional to the input voltage. This minimizes variation in current limit over line conditions. R11 and C12 create a high frequency filter to keep out any switching noise that may be fed from the input voltage through R15. This filter is not always required if the line compensation is removed.

The flyback topology is characterized by pulsating currents in the input and output capacitors. This can result in a relatively high output voltage ripple on C2. L1 and C3 are used to further attenuate the output ripple, resulting in a clean DC voltage. D3 is used to clamp the output voltage in case the load drops below the 100mA minimum level.

C1 provides an AC return path for any common mode current generated in the transformer. Since it bridges the isolation barrier, a voltage rating greater than the isolation voltage is required.

Conclusion

The flyback circuit represents a simple, low cost solution for isolated power. The versatility of the LT1725 allows the circuit to be tailored to specific applications. Accurate sampling of the output voltage from the bias winding also eliminates the need for an optocoupler circuit.

Data Sheet Download

<http://www.linear-tech.com/go/dnLT1725>

For literature on our Switching Regulators, call **1-800-4-LINEAR**. For applications help, call (408) 432-1900, Ext. 2377